

SERIOUS SERVICE®
(Fan Doctor®)



VIBES Corp® est. 1967



Vibration Industrial Balancing & Equipment Services, Corporation
720 - 999 W. Broadway, Vancouver, BC V5Z 1K5
www.vibescorp.ca email: info@vibescorp.ca
Phone: 604 - 619 - 9381 (24/7)

VIBRATION DIRECTION

Vibrations in machinery can be measured in radial, axial, and tangential directions. The intent is to detect the direction of the largest signal. Generally, the strongest signals are in the Radial direction. Machine mountings can affect vibration readings. A machine mounted on isolators such as spring isolators may have strong vertical vibration signals. Bent shafts and loose bearings can sometimes cause large axial vibration signals. Therefore it is best to take vibration readings in all three directions when possible.

MEASUREMENT POINTS

The following diagrams provide suggested vibration monitoring points. Generally, it is best to take readings on, or as close as possible to the bearings of the rotating machinery being tested. Vibration signals are strongest around bearings and tend to get weaker farther away from the bearings. Caution must be taken when working around rotating machinery, belts, pulleys and shafts.

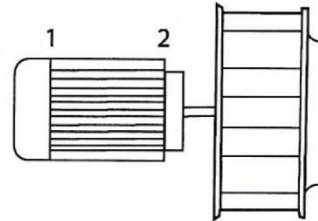

MOTOR SHAFT MOUNTED FAN

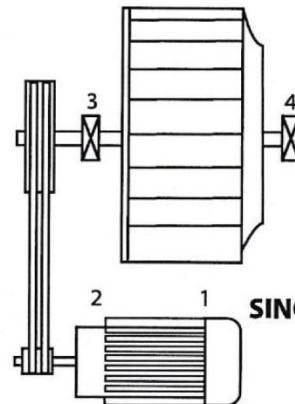

SINGLE INLET CENTRIFUGAL FAN

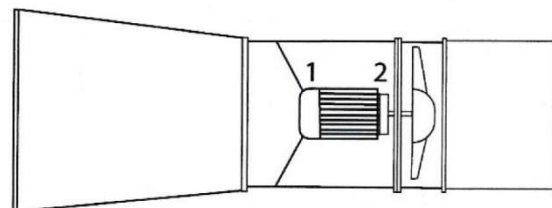
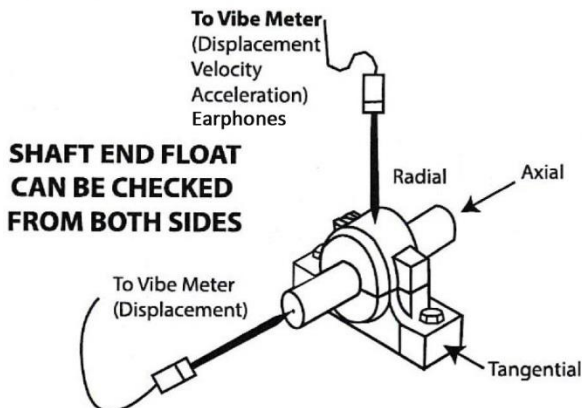

AXIAL FAN

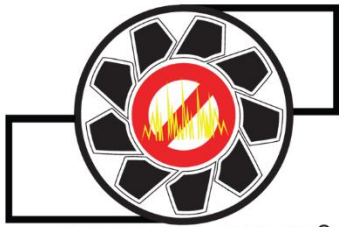

SERIOUS SERVICE®
(Fan Doctor®)



VIBES Corp® est. 1967



Vibration Industrial Balancing & Equipment Services, Corporation
720 - 999 W. Broadway, Vancouver, BC V5Z 1K5
www.vibescorp.ca email: info@vibescorp.ca
Phone: 604 - 619 - 9381 (24/7)

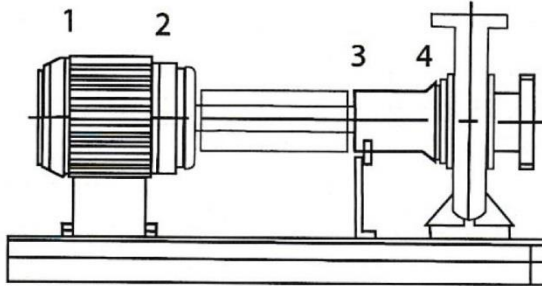

DIRECT DRIVEN PUMP

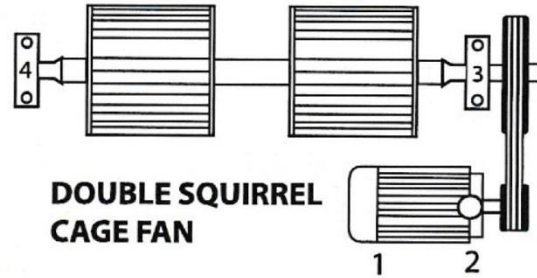

**DOUBLE SQUIRREL
CAGE FAN**

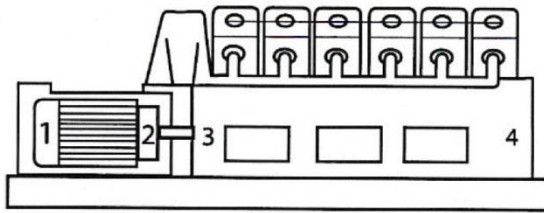

DIESEL ENGINE / GENERATOR

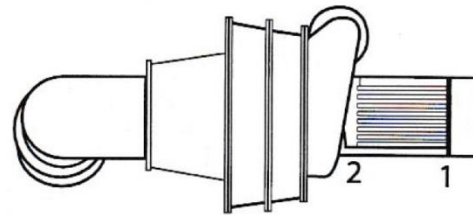

CENTRIFUGAL CHILLER

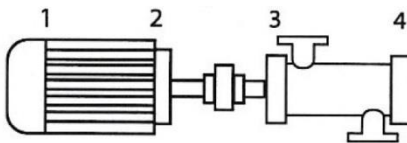

DIRECT DRIVEN COMPRESSOR

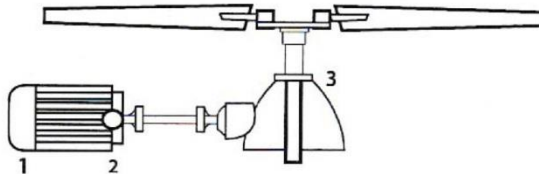

**MOTOR - DRIVE - SHAFT - GEARBOX
INDUCED DRAFT - COOLING TOWER**

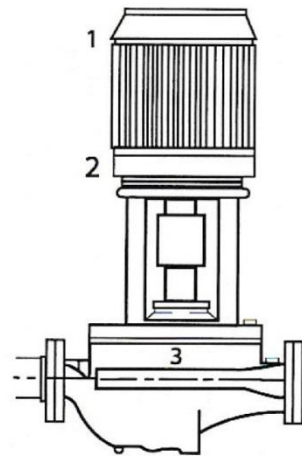

**DIRECT DRIVEN
INLINE PUMP**

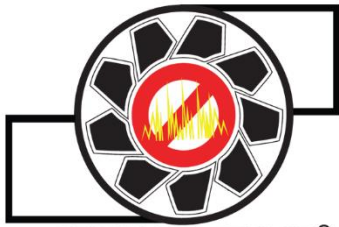

SERIOUS SERVICE®
(Fan Doctor®)



VIBES Corp® est. 1967



Vibration Industrial Balancing & Equipment Services, Corporation
720 - 999 W. Broadway, Vancouver, BC V5Z 1K5
www.vibescorp.ca email: info@vibescorp.ca
Phone: 604 - 619 - 9381 (24/7)



SERIOUS SERVICE®
Professional Machinery Health Care
(Fan Doctor®)

VIBES Corp®

www.vibescorp.ca
info@vibescorp.ca
604-619-9381 (24/7)

VIBRATION SEVERITY GRAPH FOR GENERAL ROTATING MACHINERY

This Chart is based on ISO 10816-3



Displacement
1 mil = 25 microns

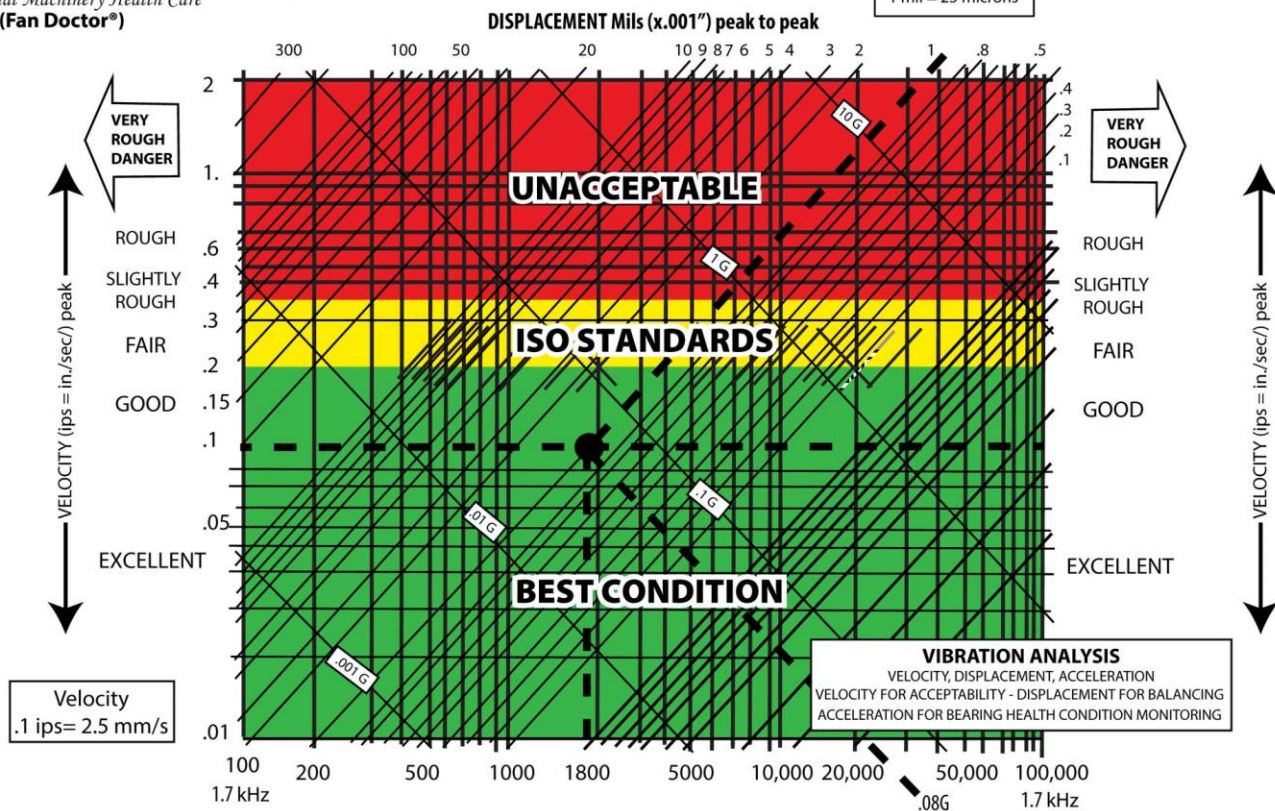

REFERENCE POINT ● = 1800 rpm machine/ motor excellent condition

ACCELERATION or FORCE OF GRAVITY "G" (ips² = in./sec² for simplicity)
ACTUAL G = 32 fps/s = 9.8 m/s/s

Note: the yellow area on chart represents issues that often can't be resolved due to time and cost.

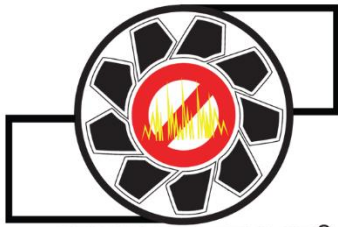

SERIOUS SERVICE®
(Fan Doctor®)



VIBES Corp® est. 1967



Vibration Industrial Balancing & Equipment Services, Corporation

720 - 999 W. Broadway, Vancouver, BC V5Z 1K5

www.vibescorp.ca email: info@vibescorp.ca

Phone: 604 - 619 - 9381 (24/7)

Vibration Sources Identification Guide

CAUSE	FREQUENCY	AMPLITUDE	PHASE	COMMENTS
Unbalance	1 x RPM	Highest in Radial Direction- Proportional to Unbalance	Single Mark (Steady)	A common cause of vibration.
Defective Anti-Friction Bearings	Very High-Often From 10 to 100 x RPM	Use Velocity	Unstable	Velocity readings are highest at defective bearing. As failure approaches, the amplitude of the velocity signal will increase and its frequency will decrease. Cage frequency is approximately 0.6 x RPM x number elements.
Misalignment of Coupling or Bearing	1, 2 or 3 x RPM	High Axial Axial 50% or more of Radial	Often 2, Sometimes 1 or 3	Use phase analysis to determine relative movement of machine or bearings. Use a dial indicator if possible. Often diagnosed as a bent shaft. Can be caused by misalignment of V belts.
Sleeve Bearing	1 x RPM	Not Large Use Displacement Mode Up to 6000 CPM	Single Reference Mark	May appear to be unbalanced. Shaft and bearing amplitude should be taken. If shaft vibration is larger than the bearing, vibration amplitude indicates clearance.
Bent Shaft	1 or 2 x RPM	High Axial	1 or 2	Similar to misalignment. Use phase analysis.
Defective Gears	High No. Gear Teeth x RPM	Radial	Unsteady	Use velocity measurement. Often affected by misalignment. Generally accompanied by side band frequency. Pitting, scuffing and fractures are often caused by torsional vibrations. Frequency sometimes as high as 1 million CPM or more.
Mechanical Looseness	2 x RPM Sometimes 1 x RPM	Proportional to Looseness	1 or 2	Check movement of mounting bolts in relation to the machine base. Difference between base and machine indicates amount of looseness.
Defective Drive Belts	1 or 2 x Belt Speed	Erratic	Use Strobe to Freeze Belt in OSC Mode	Calculate the belt RPM using: $\text{Belt RPM} = \frac{\text{Pulley Diameter} \times 3.141}{\text{Belt Length}} \times \text{Pulley RPM}$ Look for cracks, hard spots, soft spots or lumps. Loose belt. Changes with belt tension.
Electrical	1 or 2 x Line Frequency (3600 or 7200 CPM for 60Hz Power) May appear at 1 x RPM	Usually Low	1 or 2 Marks Sometimes Slipping	Looks like mechanical unbalance until power is removed. Then drops dramatically.
Oil Whip	45 - 55% RPM	Radial Unsteady	Unstable	Caused by excessive clearance in sleeve bearings or by underloaded bearings. Will change with viscosity of oil (temperature).
Hydraulic-Aerodynamic	No. Blades or Vanes x RPM	Erratic	Unsteady	May excite resonance problems.
Beat Frequency	Near 1 x RPM	Variable at Beat Rate	Rotates at Beat Frequency	Caused by two machines, mounted on same base, running at close to same RPM.
Resonance	Specific Critical Speeds	High	Single Reference Mark	Phase will shift 180° going through resonance (90° at resonance). Amplitude will peak at resonance. Resonance in frame can be removed by changing rotor operating speed or by changing the stiffness of the structure.

There are several additional detailed articles that identify more complicated vibration sources at www.vibescorp.ca titled:

- 1) LEARN ABOUT VIBRATION VOLUME 1: BASIC UNDERSTANDING OF MACHINERY VIBRATION
- 2) LEARN ABOUT VIBRATION VOLUME 2: ADVANCED VIBRATION ANALYSIS
- 3) LEARN ABOUT ELECTRICALLY INDUCED BEARING DAMAGE & SHAFT CURRENTS
- 4) FAILURE PREVENTION OF VARIABLE AND CONTROLLABLE PITCH IN MOTION AXIAL FANS